

VRTS3 Distributed System Demo Board

Description

The VRTS3 demonstration board is a self-contained board designed to support a wide range of typical distributed system measurements. Input power is provided via a USB port using a typical USB-A to USB-B cable. No additional equipment is required for this board other than the measurement instruments.

Demonstration circuits

The board contains eight individual circuit sections as identified in Table 1. These circuits are typical in most distributed systems providing an excellent test bed for demonstrating non-invasive, in-system measurement, optimization, and troubleshooting techniques.

Table 1 Circuit Sections on the VRTS3 Board

SECTION	FUNCTION
POL	5V USB input to 3.3V 2.8MHz switching regulator
REF03	2.5V low noise voltage reference
OPAMP	245MHz Bandwidth unity gain opamp buffer
LDO	LD1086 voltage regulator 5V USB input to 3.3V output
CLOCKS/BUFFERS	10MHz and 125MHz clocks
CALIBRATION	Short-Open-Load and 1 Ohm calibration ports
PLANES & CAPS	Parallel tantalum and ceramic capacitor on a small PCB plane
MICROSTRIPS	50Ω microstrips with precision aberrations - one with a ground void

The USB connection provides +5V voltage for the POL, REF03, and LDO. The output of the LDO or POL provides power to the 10MHz and 125 MHz clocks, depending on the position of the SEL1 switch.

The REF03 voltage reference provides a 2.5V output voltage to the non-inverting input of the unity gain opamp. The REF03 output can be loaded with two different capacitors (C102 and C103) using the S101 switch. The capacitors are used to demonstrate the effects that output capacitance has on the stability of the REF03.

The CLC1007 opamp input is the 2.5V output voltage of the REF03. The opamp operates at unity gain. The opamp is powered as a single rail using the +5V input as the positive supply voltage.

The CAL section of the VRTS3 port provides convenient OPEN, SHORT, and LOAD calibrators for use with a 1-port probe. The calibration is important to ensure accurate measurements on VNAs. A 1 Ohm calibrator resistor is also provided for use with a 2-port probe.

The LMR10515Y POL regulator is powered by the +5V USB input voltage. The feedback loop can be opened and closed using the top switch of S1. The bottom switch of S1 can be used to change the output voltage between 2.5V and 3.3V. There are three output resistors (R5, R6, R7) that can be added

to the output using the S2 switch to increase the output current. An input damping resistor (R2) can be added at the input using the S2 switch. The POL is able to power the clocks and buffers if the SEL1 switch is in the left position.

The LDO section includes an LT1086 that is powered by the post-filter 5V input and outputs 3.3V. The S301 switches control which output capacitors (C301, C302, C303, and C410) are present at the load. The LDO is able to power the clocks and buffers if the SEL2 switch is in the right position.

The planes and caps section contains a 470uF tantalum capacitor (C601) in parallel with a 0.1uF ceramic capacitor (C602).

The Clocks and Buffers section contains one 125MHz clock and two 10MHz clocks, along with buffers for each clock. The 125MHz clock output is connected to one NC7SZ04 inverter (U401). The 10MHz clock output is connected to two NC7SZ04 inverters (U402, U403) in parallel. A 15uF damping capacitor (C410) can be connected to U401 by using the S402 switch. The EMI probe can be used to observe the various frequencies of the clocks.

Supported Measurements

TEST	SIGNAL INJECTORS NEEDED
1 Port Impedance	DC Block
Output Impedance	See Impedance Table 2
Bode Plot	J2100A or J2101A
Non-invasive Stability	See Impedance Table 2
Switching Frequency	
Switch Rise Time	
Duty Cycle Jitter	
Noise	DC Block , 1 Port Probe , Preamp
PSRR	DC Block , J2120A , or J2111A
Step Load Response	J2111A or J2112A
Clock Jitter	
Clock Rise Time	
Jitter Sensitivity	DC Block
Power Supply Impedance	See Impedance Table 2
Crosstalk	
Clock Buffer PDN Noise	DC Block
Clock Buffer Impedance	See Impedance Table 2
Parallel Capacitor resonance	1 Port Probe
Plane Impedance	1 Port Probe
Velocity Factor and Er	
Trace Impedance	
Impedance of Broken Ground	
2 port Shunt Thru Impedance	J2120A , 2 Port Probe , DC Block
Ripple	DC Block , Preamp
EMI	Near Field Probes

Table 2 Picotest Product Applicability Impedance Matrix

Measurement	PDN Probes	Current Injector	Pre-amplifier	DC Blocker	Current Probe	Common Mode Transformer	Impedance Fixture
1-port reflection 0.5Ω-2.5kΩ	X						
2-port shunt thru 25uΩ-25Ω	X		X			X	
2-port series thru 25Ω-1MΩ	X						
3-port voltage/current 1mΩ-2kΩ	X	X	X		X	X	
Impedance adapters 0.1 Ω-400kΩ							X
1-port TDR 10mΩ-1kΩ	X			X			
2-port TDT 10mΩ-1kΩ	X			X		X	
Transient extraction mΩ-1kΩ	X	X	X	X		X	

Switches are used to allow various configuration settings for many of the circuits. A summary of the switches is included in Table 2.

Table 3 Switch Functions

POSITION	ON	OFF	
S1			
1	4.99Ω Bode plot injection resistor	Open feedback for use with the J2110A Solid State Injector	
2	Sets POL output to 2.5V	Sets POL Output to 3.3V	
S2			
1	0.51Ω filter damping resistor	5.41Ω filter damping resistor	
2	DISABLE POL regulator	ENABLE POL regulator	
3	Add additional 100mA load to POL		
4	Add additional 100mA load to POL		
5	Add additional 100mA load to POL		
S101			
1	0.1uF ceramic capacitor		
2	0.33uF ceramic capacitor		
S201			
1	5.1pF NPO capacitor		
2	10pF NPO capacitor		
S301			
1	22uF ceramic capacitor		
2	100uF 30mOhm ESR tantalum capacitor		
3	2.2uF 0.5 Ohm ESR tantalum capacitor		
4	15uF 0.4 Ohm ESR tantalum capacitor		
S401			
1	DISABLE 125MHZ clock	ENABLE 125MHZ clock	
2	DISABLE 10MHz clock	ENABLE 10MHz clock	
S402			
1	15uF tantalum damping capacitor U401		
SEL1			
	LEFT	CENTER	RIGHT
	125MHz clock POL powered	125MHz clock unpowered	125MHz clock LDO powered

The demo board is shown pictorially in Figure 1.

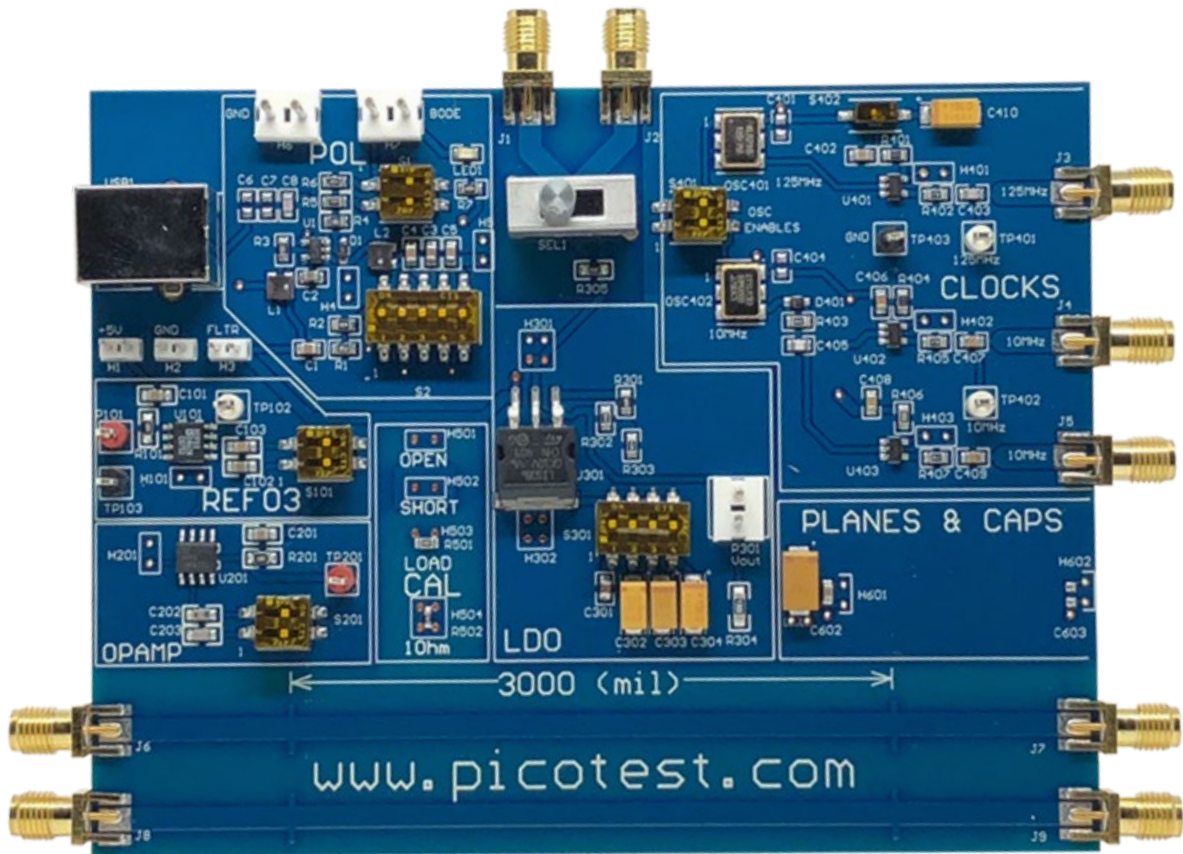

Figure 1 Demonstration Board.

Powering the Board

Step 1: Make sure Switch S1 is set to the 'ON' position.

Step 2: Plug one end of the USB cable into the USB port on the VRTS board. Plug the other end of the USB cable into any USB power supply or computer USB port.

Schematics

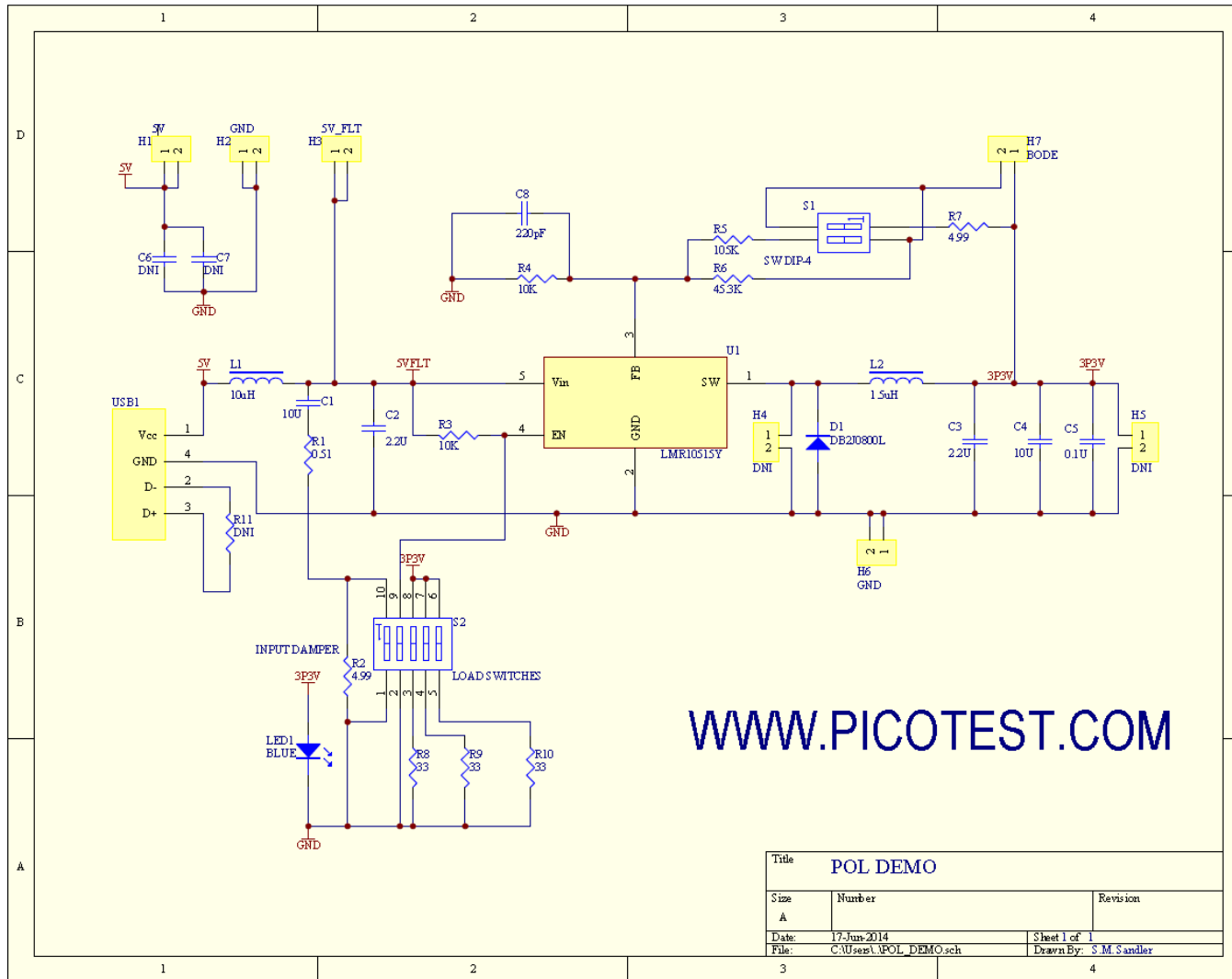

Figure 2 Schematic, POL Circuit.

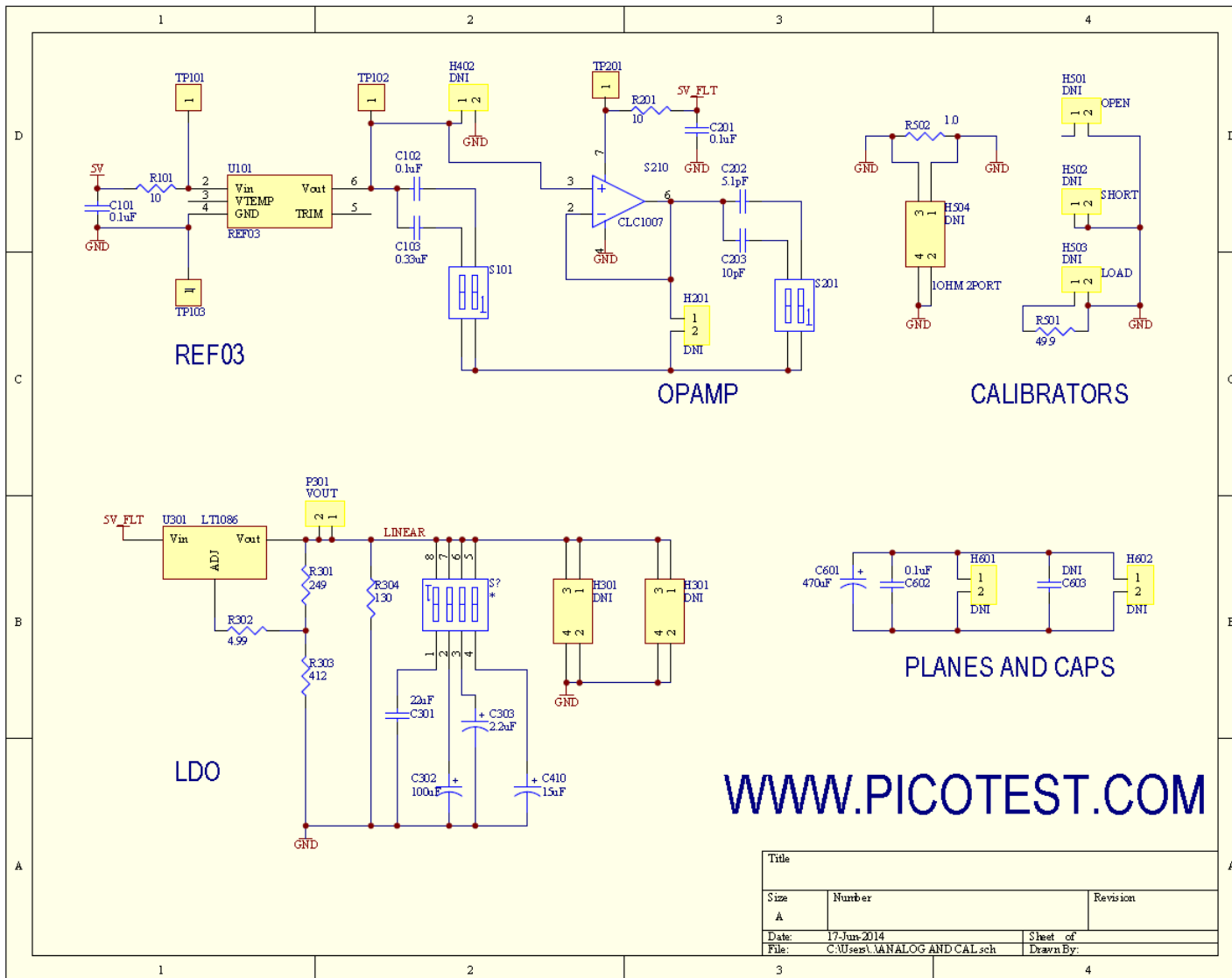

Figure 3 Schematic, Analog and Planes & Capacitors.

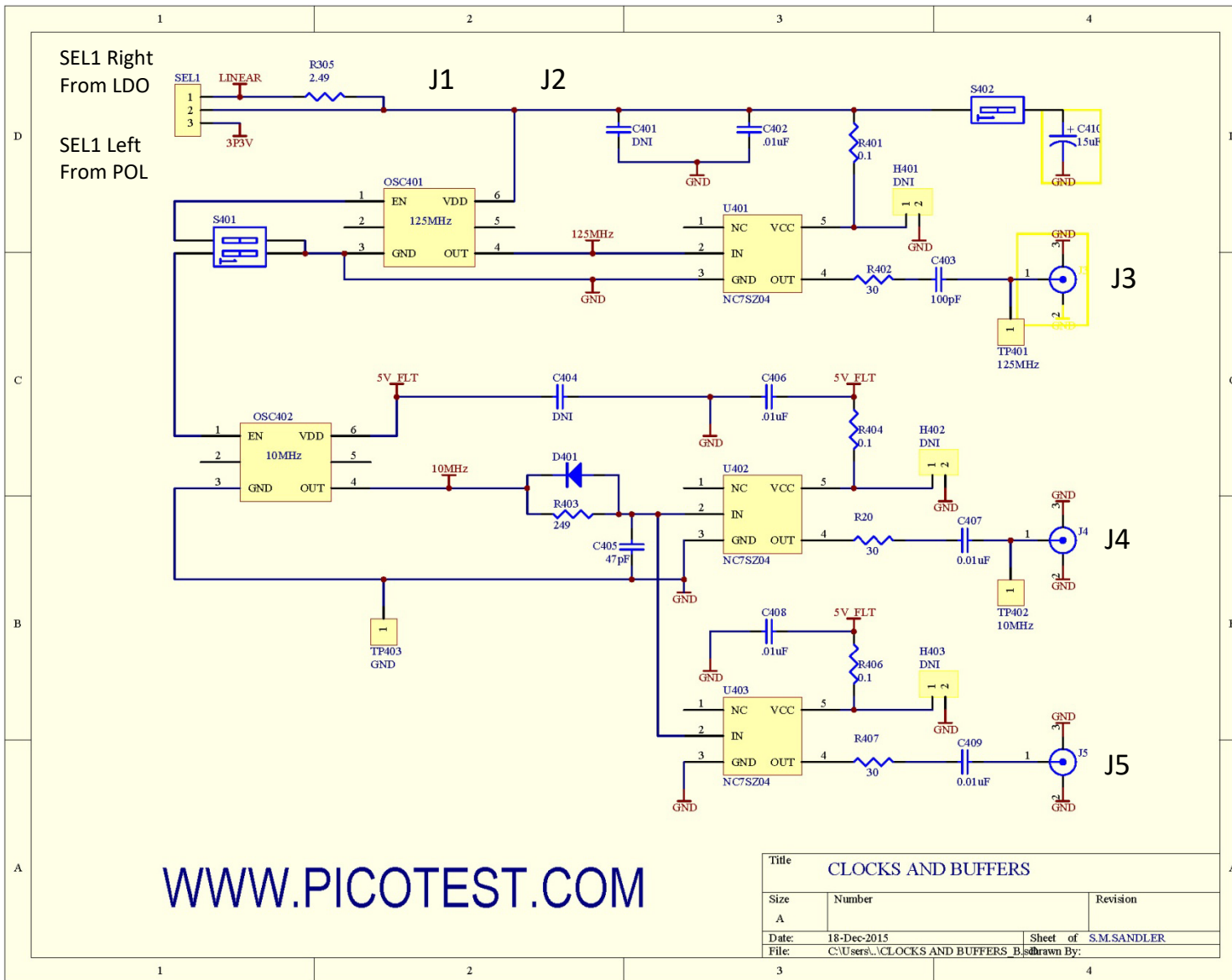

Figure 4 Schematic, Clocks and buffers

BOM

Table 4 Bill of Materials

Designators	Comment	Description	QTY
C1,C4	10uF	Capacitor, Ceramic X7R	2
C2,C3	2.2uF	Capacitor, Ceramic X7R	2
C5	0.1uF	Capacitor, Ceramic X7R	1
C6	DNI	NOT INSTALLED	0
C7	DNI	NOT INSTALLED	0
C8	220pF	220pF COG	1
D1	DB2J0800L	Diode, Schottky, 20V low Capacitance	1
H1,H2,H3		2 pin male header, unshrouded 100mil pitch	3
H4,H5		PADS ONLY NO PART INSTALLED	0
H6,H7		2 pin male header, unshrouded 156mil pitch	2
J1-J9		SMA edge launch connector	9
L1	10uH	Inductor, 10uH 630mA High Q Ferrite	1
L2	1.5uH	Inductor, 1.5uH 1.5A High Q Ferrite	1
LED1	BLUE	Led 3.3V 20mA, Blue	1
R1	0.51	Resistor, Thick Film 100ppm 1% 0.51 Ohm	1
R2, R7	4.99	Resistor, Thick Film 100ppm 1% 4.99 Ohm	2
R3, R4	10K	Resistor, Thick Film 100ppm 1% 10 kOhm	2
R5	105K	Resistor, Thick Film 100ppm 1% 105 kOhm	1
R6	45.3K	Resistor, Thick Film 100ppm 1% 45.3 kOhm	1
R8-10	33	Resistor, Thick Film 100ppm 1% 33 Ohm 1W	3
R11	DNI	NOT INSTALLED	0
S1	SPST	Dip Switch, 2-Pos SPST 100mA washable	2
S2	SPST	Dip Switch, 5-Pos SPST 100mA washable	1
SEL1	SPDT	SWITCH MINIATURE SLIDE SPDT	1
U1	LMR10515Y	IC REG SW STEP DOWN 1.5A SOT23-5	1
USB1		CONN USB TYPE B R/A BLACK	1
Rubber Bumpers		BUMPON HEMISPHERE .44X.20 BLACK	4
C101,C102	0.1uF	Capacitor, Ceramic X7R	2
C103	0.33uF	Capacitor, Ceramic X7R	1
H101	DNI	NOT INSTALLED	0
R101	10	Resistor, Thick Film 100ppm 1% 10 Ohm 0.125W	1
S101	SPST	Dip Switch, 2-Pos SPST 100mA washable	2
TP101	RED	TESTPOINT	1
TP102	WHITE	TESTPOINT	1
TP103	BLACK	TESTPOINT	1
U101	REF03	Voltage Reference Precision 2.5V Series	1
C201	0.1uF	Capacitor, Ceramic X7R	2
C202	5.1pF	Capacitor, Ceramic COG	1
C203	10pF	Capacitor, Ceramic COG	1
H201	DNI	NOT INSTALLED	
R201	10	Resistor, Thick Film 100ppm 1% 10 Ohm 0.125W	1
S201	SW DIP-4	Dip Switch, 2-Pos SPST 100mA washable	1
TP201	RED	TESTPOINT	1
U201	CLC1007	OPAMP, 245MHz, Voltage Feedback	1
C301	22uF	CERAMIC 22uF 6.3V X5R	1

Designators	Comment	Description	QTY
C302	100uF	TANTALUM 100uF 6.3V 30mOhm	1
C303	2.2uF	TANTALUM 2.2uF 25V 0.5 Ohm	1
C304	15uF	TANTALUM 15uF 20V 0.4 Ohm	1
H301	DNI	PADS ONLY NO PART INSTALLED	0
H302	DNI	PADS ONLY NO PART INSTALLED	0
P301	Comment	2 pin male header, unshrouded 156mil pitch	1
R301	4.99	Resistor, Thick Film 100ppm 1% 4.99 Ohm	2
R302	249	Resistor, Thick Film 100ppm 1% 249 Ohm	1
R303	412	Resistor, Thick Film 100ppm 1% 412 Ohm	1
R304	130	Resistor, Thick Film 100ppm 1% 130 Ohm	1
R305	2.49	Resistor, Thick Film 100ppm 1% 2.49 Ohm	1
S301	SPST	Dip Switch, 4-Pos SPST 100mA washable	1
U301 alt	LD1086	Voltage Regulator, Adjustable	1
C401	DNI	NOT INSTALLED	0
C402, C406-C409	.01uF	Capacitor, Ceramic X7R	5
C403	100pF	Capacitor, Ceramic COG	1
C404	DNI	NOT INSTALLED	0
C405	47pF	Capacitor, Ceramic COG	1
C410	15uF	TANTALUM 15uF 20V 0.4 Ohm	1
D401	BAS16	DIODE 100V 250MA SC-90	1
H401,H402,H403	DNI	PADS ONLY NO PART INSTALLED	0
OSC401	125MHz	OSC 125.0000 MHZ 3.3V HCMOS SMT	1
OSC402	10MHz	OSC 10.000 MHZ 5.0V SMD	1
R401,R404,R406	0.1	Resistor metal foil	3
R402,R405,R407	30	Resistor, Thick Film 100ppm 1% 30 Ohm	3
R403	249	Resistor, Thick Film 100ppm 1% 249 Ohm	1
S401	SPST	Dip Switch, 2-Pos SPST 100mA washable	2
S402	SPST	Dip Switch, 1-Pos SPST 100mA washable	1
TP401,TP402	WHITE	TESTPOINT	1
TP403	BLACK	TESTPOINT	1
U401-U403	NC7SZ04	single gate high speed inverter	3
H501,H502,H503	DNI	NOT INSTALLED	0
H504	DNI	NOT INSTALLED	0
R501	49.9	Resistor, Thick Film 100ppm 1% 49.9 Ohm	1
R502	1.00	Resistor, Thick Film 100ppm 1% 1.0 Ohm	1
C601	470uF	TANTALUM 470uF 6.3V 45mOhm	1
C602	0.1uF	Capacitor, Ceramic X7R	1
C603	DNI	Capacitor, Ceramic X7R	
H601,H602	DNI	NOT INSTALLED	

Safety Information



Caution: To avoid equipment damage and/or severe injuries or death ensure that the absolute maximum ratings defined in this manual are observed at all times.

Characteristic	Rating
Absolute Maximum Input Voltage	5.25V
Maximum Output Voltage	+/-5V
Maximum Input Current	500mA
Temperature range	0-50°C
Absolute Maximum Voltage	<50 VAC and 75VDC